

A guide to circuit packages used in the Ferranti Atlas.

Simon Lavington.

June 2015.

1. Introduction.

The intention is to give a guide to the function and type-numbers of all the printed-circuit packages used in the Ferranti Atlas computer, which was first operational in 1962. The information has been collected from various sources, principally from references [1] to [4]. (A list of references is given at the end). The data in this paper is, as yet, incomplete. This is because it has not yet proved possible to locate copies of all the original Ferranti documents that defined every package-type. The search for more information is on-going.

To quote ref [1]: “Atlas is a fully-transistorised computer of package construction, a total of 3,955 packages used in the standard Atlas”. This figure was estimated in April 1961, before the first production Atlas was fully assembled. The package-count as calculated in November 1962 [ref. 2] was 5660. In truth, the total count varied per installation. The smallest of the three Atlas 1 installations was estimated [ref. 6] to have a total of 5,172 packages, which probably included the two special on-line peripherals (an X-ray Diffractometer and the A/D/A Speech Converter).

The majority of the packages (also called *printed-circuit boards*, abbreviated *pcbs*) used in the central processor carried circuits of only seven basic types. Each of the seven basic types then had several variations concerned with logic gating, fan-out, etc.

The seven basic types are listed in ref. [1] as:

- a. Standard inverters (including variations such as flip-flops and cable drivers);
- b. Strobe drivers;
- c. Strobe emitter followers;
- d. Powerful inverters and powerful long-tailed pairs;
- e. Decoder emitter followers.

Some circuit details are given in Section 2 below.

In addition to the basic logic circuits, special circuits were used for the parallel adders, for the core and drum and magnetic tape stores and for the read-only Fixed Store. An introduction to the system architecture and characteristics of the whole computer and its characteristics will be found in ref. [5], together with a list of technical references.

Most of the Atlas circuits were designed by a joint team from Manchester University and Ferranti Ltd. The core store circuitry was designed by Plessey Ltd. and the circuits in the Ampex TM2 magnetic tape decks were designed by a team at Ferranti Edinburg's Craigroyston Laboratories. Most of the packages were made by the Printed Circuit Division at Ferranti's West Gorton factory in Manchester, the abbreviation *GPC* on many of the boards signifying *Gorton Printed Circuits*. At the relevant time (1960 – 1965) West Gorton was also producing completely different packages for the Orion computers. Atlas and Orion did, however, share some units of peripheral equipment – for example Ampex TM2

magnetic tape decks – and hence shared some of the package-types. The logic circuitry for the Orion 1 and Orion 2 CPUs was completely different from that of the Atlas CPU. Orion 1 used *Neuron* logic, similar to that of the Ferranti Sirius computer, whereas Orion 2 logic was similar to the type later adopted for the early ICT 1900 series. West Gorton assigned type-numbers in the range 800 – 899 exclusively to Atlas packages. Atlas and, it is thought, Orion, also used some 500-series and some 900-series package-types. In this paper we concentrate only on packages used by Atlas.

As far as can be determined, the West Gorton numbering conventions for printed-circuit boards followed the scheme given in Table 1.

GPC series numbering	Computers	Comments.
0xx	Sirius & Orion 1	Neuron circuits
1xx	Orion 1	
2xx	Sirius & Orion 1	
3xx	Orion 1?	300-307, 314, 340-343 = core buffer and random access stores. 310, 311 to 311 = miscellaneous power supply packages?
4xx	Orion 1	Orion 1 drum package, cable driver and receiver, bias circuits.
5xx	(slower) peripherals	
6xx	??	
7xx	1900 series & possibly Orion 2	Early 1900 series computers (approx. 1964 – 1968?)
8xx	Atlas	
9xx	Atlas & Orion peripherals	Includes some packages designed by Plessey Ltd.

Table 1. A guide to the type-numbers of Ferranti printed circuits in the period 1960 – 1965.

The dimensions of Ferranti standard packages were as follows:

Sirius and Orion 1: 5" high, 4.5" long.
 1900 series: 4 3/8" high, 5.5" long.
 Atlas (8xx & 9xx): 5" high, 8" long.

The 700 series packages (for Orion 2 and the 1900 series) used the more recent Burndy edge-connectors with connections on both sides (44 in total - 22 on each side) whereas standard 800 series Atlas boards had 32 edge-connectors on one side of the board only – (as did 000, 400, 500, 900 series, it is believed).

An analysis of the package types in a production Atlas 1, as estimated in November 1962 [ref. 2] was as follows:

Main CPU:	4020 of type 8xx + 78 of type 9xx;	total = 4098.
Plessey stores:	126 of type 8xx + 909 of type 9xx;	total = 1035.
Magnetic tape system:	249 of type 9xx;	total = 249.
Control desk:	18 of type 8xx;	total = 18.
I/O peripherals:	260 of type 5xx;	total = 260.
		Grand total = 5660.

2. Some Atlas circuit details and the notations used.

A simplified schematic of a basic Atlas logic circuit is given in Figure 1, for the case of two 2-input AND gates followed by a two-entry OR gate followed by an inverter. The standard logic levels are approximately + 2 volts for logic 0 and -0.5 volts for logic 1. The diodes are typically Mullard germanium OA47 or OA90.

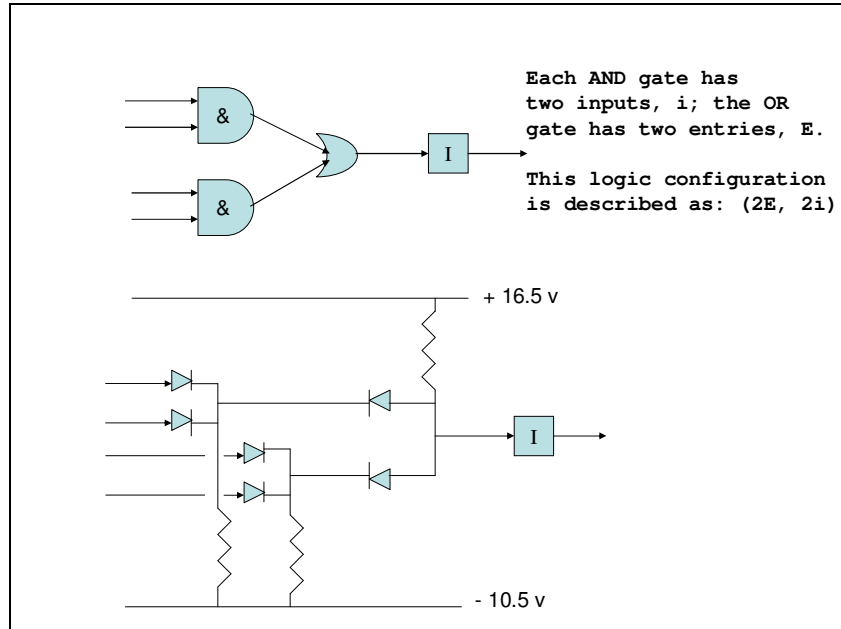

Figure 1. Simplified schematic logic diagram, illustrating the shorthand notation used in Table 2 (in Section 5).

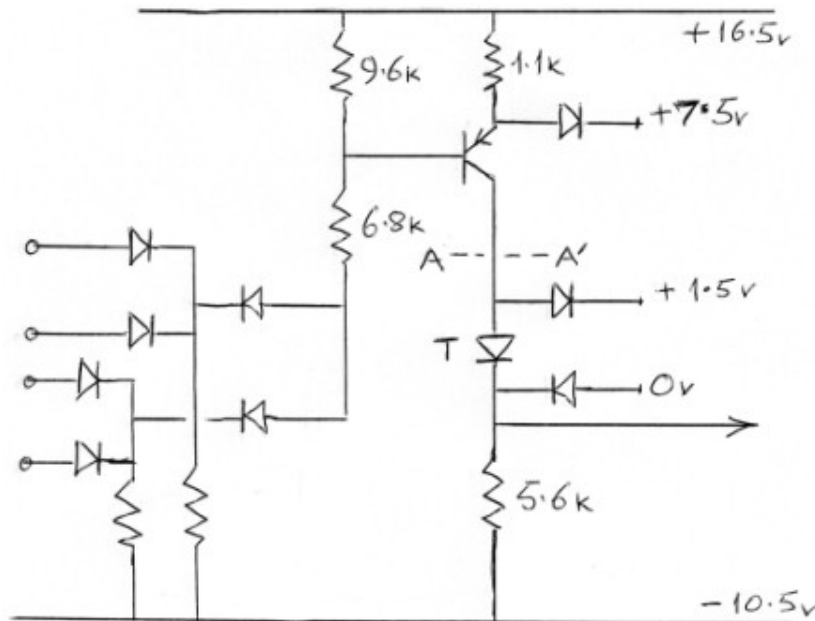

Figure 2. Circuit diagram of the inverter of Figure 1.

In Figure 1, the combination of two 2-input AND gates followed by a two-entry OR gate is represented in ref. [1] by the shorthand notation

(2E, 2i)

and this notation is used later in Table 2 (see section 5) to characterise the logic gating on each of the Atlas packages.

Before listing the packages, we give some notes on device-types used in Atlas since this information is of help to computer historians and museum curators when trying to identify the date and provenance of a particular package.

3. Device types and in-service package modifications.

Not all versions of a particular Atlas package-type are identical. Below is a summary of the main changes that were introduced as time went by.

3.1. Tom's diode. In about mid-1962 the series diode T in Figure 2 was added to the basic inverter because it had been observed that switch-on/switch-off ripples in the mercury switches in the Atlas power supply could cause the 1.5v rail to dip momentarily below earth potential. In early Manchester packages the diodes T were retro-fitted for protection. From about 1963 onwards the diodes were built in at the manufacturing stage.

3.2. OC170 screen removal. The OC170 was originally a four-lead device: emitter, base, collector, and a *screen* which was normally earthed. When investigating the incidence of curious faults in about 1964 it was noticed that molecular crystals had gradually grown between screen and collector. The solution was to snip off the OC170 screen leads.

3.3. Re-design of pcb track layout.

There was at least one re-design of the basic board topology, in order for example to improve signal-to-noise ratio or tendency to oscillate. Such factors were critical in the high-speed parallel adder. The layout of the type 814 package (adder output) was re-designed – see photographs in Section 4.

3.4. Upgrading of transistors

Designing for high speed in the late 1950s was a compromise: the fastest transistors were generally American – for example the special surface-barrier type manufactured by Philco – and much too costly for general use in the UK. The fastest commodity British transistor in the late 1950s, the Mullard OC170, was a germanium pnp alloy-diffused RF device that could not be allowed to saturate ('bottom') if the switching time was to be minimised. The basic Atlas inverter used an OC170 or its later equivalent the Mullard ASZ20, in a complex current-switching configuration shown in Figure 2. It was not until the early 1960s that silicon began to replace germanium, whereupon higher-speed commodity transistors became available.

The initially-expensive Philco surface-barrier SB240 transistor or equivalent (eg 2N240, 2N501) was essential in the Atlas adder's carry-path (pcb 812). This was because the SB240's symmetrical nature meant that both the *base-emitter* and the *base-collector* diodes of the SB240 could be forward biased with approximately the same voltage. Thus the voltage drop across the closed switch, from emitter to collector, was approximately zero. It could operate in a manner electrically equivalent to a relay (but of course very much faster!). In early editions of some other Atlas pcs such as powerful inverters and

emitter followers, SB240 (and later the 2N501) were used as replacements for OC170 where extra speed and/or power were required. These were later superseded by equivalents such as the Plessey T2040 (or sometimes the LANST 2040 or SDALE 2040). In summary, higher-specification transistors were introduced into Atlas packages from time to time, as device-manufacturers evolved their offerings and costs reduced.

Although most Atlas diodes were typically germanium OA47 or OA90, other specialist diodes were also used. For example, the 814 package uses zener diodes – (Mullard OAZ203 on the older version of this board and Ferranti CV7070 on the newer version).

Production of Atlas packages at West Gorton spanned the period approximately 1960 – 1966. Apart from Ferranti serial numbers, a look at the type of transistor used can identify the approximate date of manufacture. Some individual transistors had date-markings on their cans. Philco used a date-code on their devices, so that '6042' would have been 'week 42 of 1960' and 6407 'week 7 of 1964'. On a visit to the Chilton Atlas in storage at NMS Edinburgh in February 2015 the following were amongst the sample dates noted: 62/24; 62/31; 63/21; 63/31.

4. Illustrative images of Atlas packages.

In the photos below, each board has three plastic coloured tags on its lower front edge. The colours follow the usual electrical coding of digits, namely:

Black = 0; brown = 1; red = 2; orange = 3; yellow = 4; green = 5; blue = 6;
Purple = 7; grey = 8; white = 9.

Thus, package 812 is identified by tags coloured grey/brown/red. Note that some of the colours look faded in the images.

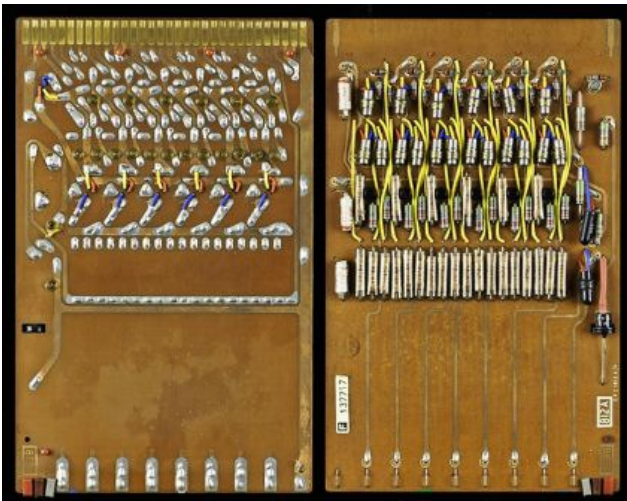

Figure 3: 812 (adder carry), rear & front.

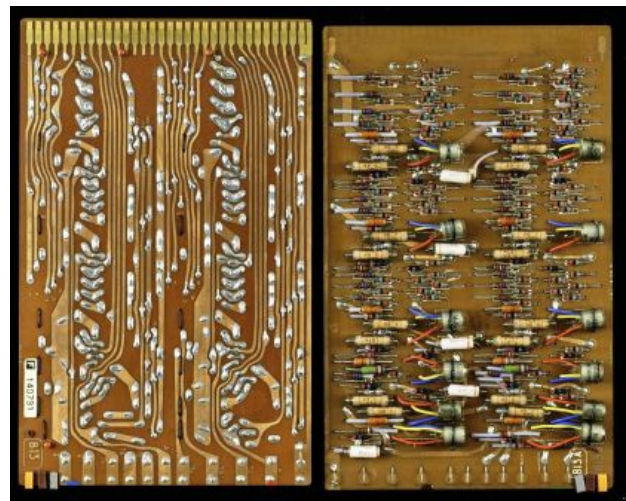

Figure 4: 813 (adder input), rear & front.

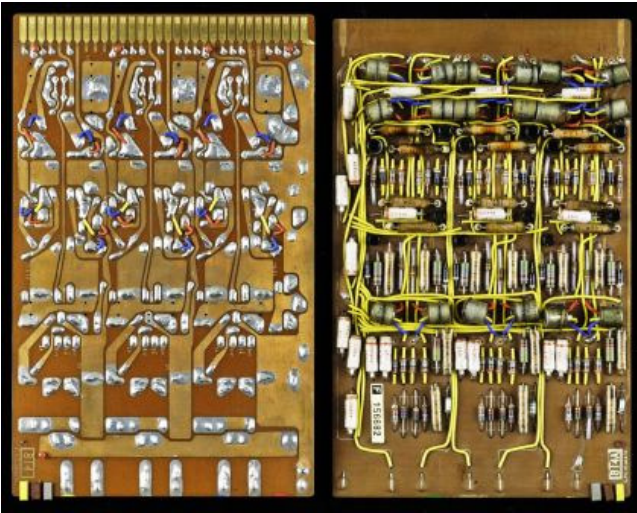

Figure 5: 814 (adder O/P, new version rear & front).

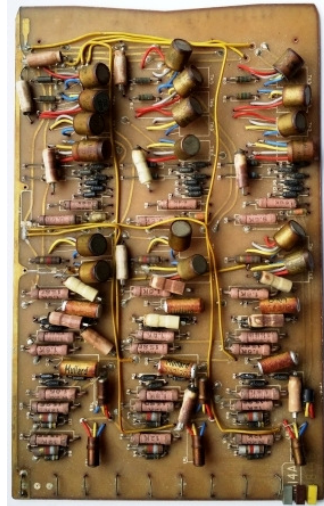

Figure 6: 814 (old version, front)

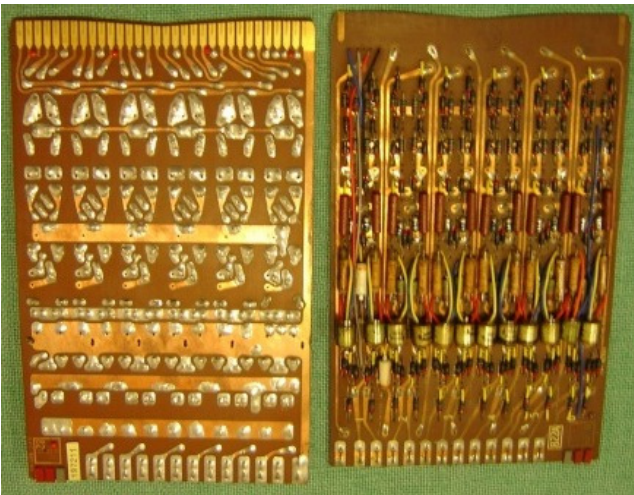

Figure 7: 822 (six flip-flops, rear and front).



Figure 8: 826 (powerful long-tailed pair)

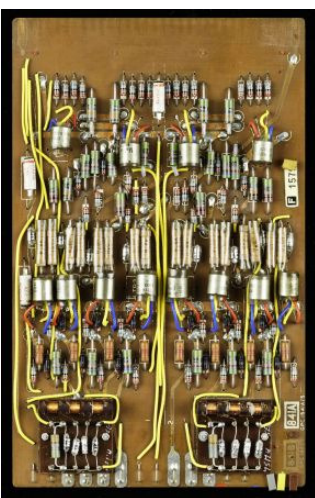

Figure 9: 841 (Juke box type 1)

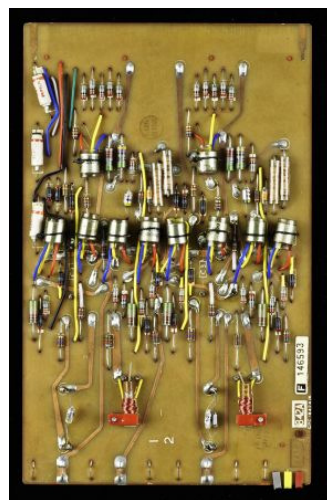

Figure 10: 842 (long delay)

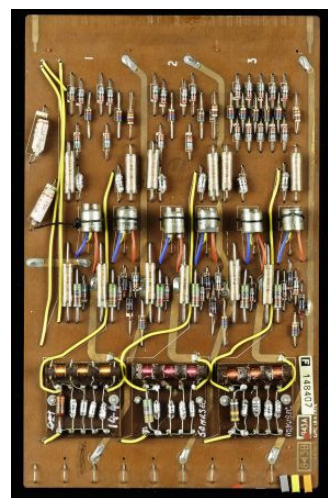

Figure 11: 843 (short delay)



Figure 12: 846 (strobe emitter follower)



Figure 13: 962 (Plessey read/write delay line)

5. Summary Tables listing the known Atlas packages.

Lists for all known 800-series, 900-series and 500-series packages used in Atlas are given in Tables 2, 3 and 4. Gaps in the Table denote lack of knowledge on the part of the author. It is hoped to update the Tables as more of the original documentation comes to light.

The notation for logic gating in Table 2 follows that illustrated in Figure 1. The following additional abbreviations are used:

- I = Inverter
- PI = Powerful inverter
- LTP = Long-tailed pair
- PLTP = Powerful long-tailed pair
- CD = Cable driver
- EF = Emitter follower

Table 2. 800 series packages employed in the Atlas computer:

Type	Description, where known	Comments
800	Fixed store ?	(Approx. 99 of these packages per Fixed Store)
801	Fixed store ?	(Approx. 100 of these packages per Fixed Store)
802	Fixed store ?	(Approx. 8 of these packages per Fixed Store)
803	Fixed store ?	(Approx. 60 of these packages per Fixed Store)
804	Fixed Store rhythm unit short and long delays: 2x(1E, 2i), 1x(1E,1i)	2 short delay ccts and one long delay cct per package, together with a modified powerful inverter.
805		
806	Oscillator?	
807		
808		
809		
810		
811	Adder input for half-adders?	
812	Adder Carry	See Fig. 3.

813	Adder input	See Fig. 4.
814	Adder output.	See Fig. 5. The first version of this package (Fig. 6) had a tendency to oscillate. It was re-designed.
815	Inverter (12E, 2i)	1 cct per package
816	Inverter (6E, 2i)	2 ccts per package
817	Inverter (2E, 2i)	5 ccts per package
818		?
819	Accumulator flip-flop (max. gating)	2 ccts per package
820	Cable driver (1E, 1i, strobed)	12 ccts per package
821	Inverter (1E, 1i, strobed)	12 ccts per package
822	Flip-flop (1E, 1i) strobed	6 ccts per package. See Fig. 7.
823		Inverter?
824	Long-tailed pair (1E, 2i) cable driver	6 ccts per package
825	Long-tailed pair (1E, 2i)	6 ccts per package
826	Powerful long-tailed pair	6 ccts per package. See Fig. 8.
827	Powerful inverter	12 ccts per package
828		This might be functionally the same as 826?
829		Powerful inverter?
830	Cable driver (2E1i, strobed)	8 ccts per package
831	Inverter (2E, 1i, strobed)	8 ccts per package
832	Flip-flop (2E, 1i) strobed	4 ccts per package
833		?
834	Long-tailed pair (2E, 2i)	4 ccts per package
835	Cable driver (3E1i, strobed)	6 ccts per package
836	Inverter (3E, 1i, strobed)	6 ccts per package
837	Flip-flop (3E, 1i) strobed	3 ccts per package
838	Flip-flop (2E, 1i) strobed Flip-flop (1E, 1i) unstrobed	3 ccts per package
839	Long-tailed pair (3E, 2i)	3 ccts per package
840	(Fixed store, CD)	
841	Juke-box type 1 (flip-flop and delay)	1 cct per package. See Fig. 9.
842	Long delay type 1 (1E, 2i)	2 ccts per package. See Fig. 10.
843	Short delay; 2x(2E,2i), 1x(1E,5i)	3 ccts per package. Separate plug-in assemblies are available for delays of 60, 80, 100 and 120 nsec. See Fig. 11.
844	Differentiator (adjustable pulse-length)	4 ccts per package
845	(Fixed store; drum; CR)	
846	Strobe emitter follower	12 ccts per package. See Fig. 12.
847	Strobe driver	8 ccts per package
848		(this package used with the drum electronics)
849	Cable driver receiver	13 ccts per package
850	Decoder emitter follower (2E)	8 ccts per package
851	Decoder emitter follower (5E)	4 ccts per package
852	Decoder emitter follower (8E)	3 ccts per package
853	Cable driver (1E,2i, strobed)	8 ccts per package
854	Inverter (1E, 2i)	8 ccts per package
855	Inverter (1E, 5i)	4 ccts per package
856	Inverter (1E, 8i)	3 ccts per package
857	Inverter ?	?
858		?
859	Inverter ?	?
860		PD?
861	Inverter (12e, 2i) fused input	
862		Probably a set of fuses (eg for the Periph Coord)
863	Fused peripheral lines	Used for example in the Control desk
864		
865		(this package used with the drum electronics)

866		
867	Fused peripheral lines	
868		(Drum, RS)
869	Drum diode matrix?	Short board. See Alan Thomson.
870	(occurs with drum electronics)	
871	Drum diode matrix?	100. Short board. See Science Museum.
872		24
873		(this package used with the drum electronics)
874		(this package used with the drum electronics. Also possibly used in the Creed 3000?)
875		(this package used with the drum electronics)
876		(this package used with the drum electronics)
877		(this package used with the drum electronics)
878		(this package used with the drum electronics)
879		(Drum, LOR)
880		
881		
882		
883		
884		
885	(Drum, ABC)	(Drum, ABC)
886		(A Plessey board?)
887		
888		
889		
890		
891		
892		
893		?
894		
895		
896		
897		
898		?

Some 900 series packages known to have been employed in Atlas, mostly in connection with the Plessey core stores.

Type	Description, where known	Comments
900		
901	(Occurs in mag tape deck)	
902		(A Plessey board)
903		
904		
905	(occurs often with drum electronics)	
906		
907		
908		(A Plessey board)
909	(Occurs in mag tape deck)	

910	Shunt regulator	
911		
912		(A Plessey board)
913	Amp ?	(A Plessey board)
914	I and EF ?	(A Plessey board)
915	Catch reference	Plessey
916	Amp; LTP; PI ?	Plessey
917a	Amp	Plessey
917b	Amp	Plessey
918	LTP	Plessey
919	EF	Plessey
919a		Plessey
920		Plessey: Constant current unit (0.5 or 0.8A ?)
921		Plessey: 3A Constant current unit.
922		Plessey
923		Plessey
924		Plessey
924a		Plessey
925		
926		A Ferranti board
927		
928		
929		
930	(Occurs in mag tape deck)	TM2 Mag tape
931	(Occurs in mag tape deck)	TM2 Mag tape
932	(Occurs in mag tape deck)	TM2 Mag tape
933	(Occurs in mag tape deck)	
934		TM2 Mag tape
935	(Occurs in mag tape deck)	TM2 Mag tape
936	(Occurs in mag tape deck)	TM2 Mag tape
937	(Occurs in mag tape deck)	TM2 Mag tape
938	(Occurs in mag tape deck)	TM2 Mag tape
939	(Occurs in mag tape deck)	TM2 Mag tape
940	(Occurs in mag tape deck)	TM2 Mag tape
941		
942		
943		
944		
945		
946	??	
947		
948		
949	(Drum, several times, RA)	
950		
951		
952		
953		
954	(occurs with drum electronics)	
955	(occurs with drum electronics)	
956		
957		
958	??	
959		
960		
961	LTP	Plessey
962	Read or write delay line	Plessey. See Fig. 13.
963		Plessey
964		Plessey

965	Amp	Plessey
966		Plessey
967	Inverter	Plessey
968	Amp	Plessey
969		
970		Plessey
971		Plessey
972		Plessey
973	LS	Plessey
974		Plessey
975		Plessey
976		Plessey
977	(occurs with drum electronics)	Plessey
978		Plessey
979		Plessey
980		
981		
982		
983	(occurs with drum electronics)	
984		
985		
986	(occurs with drum electronics)	
987		
988	(Drum, PS)	
989		
990		
991		
992		
993		
994		
995		
996		
997		
998		
999		Peripherals?

Some 500 series packages, mainly employed in (or for) Atlas peripheral equipment.

Type	Description	Ccts. per pcb	Notes	'Quantity in machine' according to [ref. 2]
520				
521				
522				
523				
524				
525				
526				
527			Peripherals	4
528				
529				
530			Peripherals	-
570			Peripherals	119
571			Peripherals	5

572			Peripherals	9
573			Peripherals	18
574				
575			Peripherals	-
576			Peripherals	21
577			Peripherals	14
578			Peripherals	15
579			Peripherals	13
580			Peripherals	32
581			Peripherals	5
582			Peripherals	4
583				
584				
585				
586				
587				
588				
589				
590				

6. References.

1. *The basic Atlas packages: technical description*. Ferranti Document EP32, dated April 1961. This typed quarto document, of 25 pages, gives circuit diagrams and electronic explanations of basic circuits and some associated packages.
2. *Atlas computer notes*. A handwritten notebook kept by Mrs Irene Bajer, who worked for Ferranti Ltd. at their West Gorton factory from 1958 – 1963. Mrs Bajer became a Supervisor Chargehand Inspector, working on the production of the Ferranti Atlas. Eight pages of her notebook constitute a tabulated list entitled *Stock of all types of packages at Manchester University Atlas, 26/11/62*. The list is in four columns, headed respectively: *Type; In machine; Spares; Still required*. The final column has very few entries, indicating that by 26th November 1962 the complement of printed-circuit boards for the first production Atlas was almost complete. The Computer History Museum at Monash University, Melbourne, acquired the papers of Mrs Bajer in September 2008. This notebook has the Monash Museum catalogue number MMoCH 2008.017.
3. Ferranti Ltd., Folder of Atlas logic diagrams. This dull green folder, the property of Eric Sunderland (formerly a maintenance engineer on the Manchester Atlas), contains about 240 Atlas engineers' diagrams, each approximately 40 cms by 20 cms. The folder is currently in the archive of the School of Computer Science, University of Manchester.
4. Almost all of the logic cabinets from the Chilton Atlas, complete with their pcbs, are preserved in storage at the National Museums Scotland in Edinburgh. See: <http://elearn.cs.man.ac.uk/~atlas/docs/Chilton%20Atlas%20hardware%20at%20the%20National%20Museums%20Scotland.pdf>

5. The Atlas story. Simon Lavington, 2012. See:
<http://elearn.cs.man.ac.uk/~atlas/docs/The%20Atlas%20story.pdf>
6. D B G Edwards, e-mail to Simon Lavington in November 2012.

Simon Lavington
lavis@essex.ac.uk

June 2015.